

USB to Synchronous Cable Enables IP Data Communications for Tactical Radios

Cost-Effective, High-Speed Interoperability on the Battlefield

Warfighters can benefit greatly from having fully interoperable radio IP-based data communications at the theater level. Unfortunately, the vast majority of the tactical data communications and situational awareness systems currently in use are comprised of various makes and models of tactical radios, making it difficult to achieve interoperability at the theater-level.

Sealevel Systems, Inc. has developed a high-throughput synchronous interface that works seamlessly with software developed by the Defense Information Systems Agency (DISA): Sealevel's ACC-188 USB synchronous radio adapter cable and DISA's free PDA-184 tactical data communications software application. The plug-and-play cable can be quickly connected to your computer or handheld device via USB connection and to your tactical radio, making it easy for warfighters to enhance their critical high-speed data communication on the battlefield.

The ACC-188 USB synchronous serial radio adapter (Item# 9065) and free software from DISA enables tactical radios with the capability to transmit and receive IP data such as email, text messages, GPS maps, images, coordinates, and other communications. The system is non-proprietary and MIL-STD-188-184 compliant, allowing for interoperability with various radios without multiple connections or additional equipment.

ACC-188 USB Synchronous Interface Cable

Sealevel was commissioned by the DISA to develop a synchronous adapter that was compatible with their applications. The resulting ACC-188 adapter is a lightweight single-cable solution that outperformed previously used tactical data communication solutions. The ruggedized system is housed in a rubberized over-molded die-cast aluminum shell that is resistant to liquid, dust, and dirt. The single-cable ACC-188 solution does not require multiple connections or heavy peripheral equipment to interface with tactical radios; the ACC-188 connects to the standard USB port on any laptop or desktop computer.

The cable and integrated assembly consists of a printed circuit board that is tested and then encapsulated using an over-mold process, commonly called a "bump" in the cable. This process results in a rugged, fully shielded, battlefield-ready product capable of being deployed in the harshest environments. One end of the cable includes a standard type-A USB connector, suitable for use with any USB enabled computer. The other end of the cable includes a connector specific to a brand or model of tactical radio.

The ACC-188/PDA-184 solution combines to provide 100% interoperability allowing data to be transmitted and received between different radio models and brands. A six-foot cable is terminated with the appropriate connector to make the ACC-188 compatible with the most prevalent brands and models of tactical radios including:

- AN/PRC-117F
- AN/PRC-117G
- AN/PRC-119
- AN/PRC-148
- AN/PRC-150
- AN/PRC-152
- AN/PSC-5C and D
- AN/ARC-231
- AN/ARC-210
- KY-99A

Converting the radio waveform to USB data is performed by circuitry and firmware contained in a waterproof “bump” in the cable. USB is an asynchronous interface that relies on the USB host controller to poll the USB I/O device for data. Since the radio transmits continuous high-speed synchronous data, often for extended time periods, the conversion to asynchronous USB required careful attention to a variety of critical timing elements.

Figure 1. Military laptop connected to a tactical radio using the ACC-188.



The heart of the design is an 8-bit microcontroller with integrated USB port and a Field Programmable Gate Array (FPGA) device. Considering that the USB port on the host computer fully powers the ACC-188, the design is optimized to consume less than 0.3 watts of power to minimize battery drain when used with laptops operating off of battery. This feature is vitally important in battlefield situations where soldiers may not have the ability to recharge their laptop batteries for extended periods of time.

The FPGA integrates a 256-byte Receive FIFO for receiving high-speed serial data from the radio. Using the clock signal supplied by the radio, the incoming data is clocked into the FIFO and stored until the microprocessor organizes the data into byte format and transfers the formatted data to the PC via USB packets. Similarly, on message transmission, the USB packets are sent to the Transmit FIFO and subsequently clocked out one bit at a time to the radio.

Figure 2. ACC-188 hardware architecture.

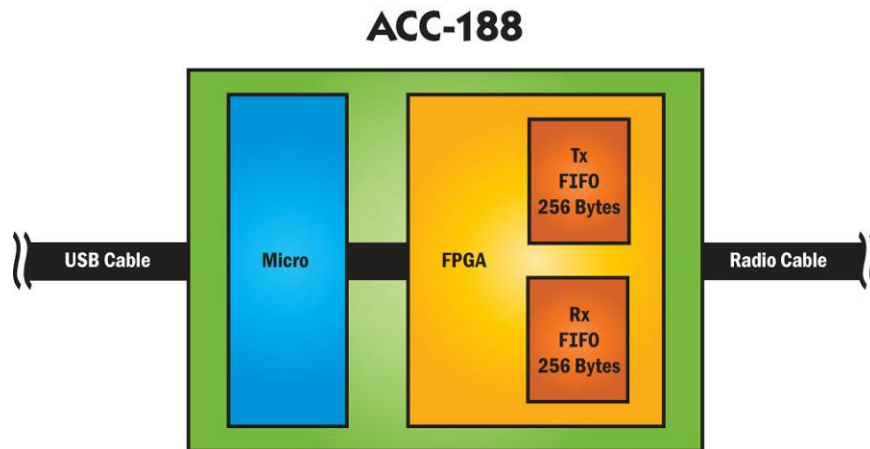

Intuitive Software for Fast Response

DISA worked with Able Communications (Sterling, VA) and Sealevel to develop the PDA-184 software application, which implements the MIL-STD-188-184 Interoperability and Performance Standard for the Data Control Waveform. The PDA-184 software provides data compression, packet communications, and adaptive error-correction. Point-to-point, broadcast, and multicast messaging within a network are all supported. The PDA-184 dynamically throttles data throughput, based on the communications channel conditions, for optimal throughput. In ideal conditions, data rates of up to 76K bps can be achieved. The PDA-184 software was designed for use with military High Frequency (HF), Very High Frequency (VHF), Ultra High Frequency (UHF) and SATCOM radios and networks.

The PDA-184 application software runs on Windows XP, 2000 and Vista operating systems and uses Sealevel's SeaMAC V4 USB synchronous driver software for the low-level interface to the hardware. SeaMAC communicates with the radio using synchronous raw mode, a completely unformatted method of operation. The incoming data is grouped into byte format and passed to the PDA-184 software application. All byte alignment and sync character detection is executed entirely by the PDA-184 application and can operate on a received signal with as high as a 10% bit error rate. The processing performed by the software overcomes the effects of noise on the communications channel, thereby providing highly reliable, error-free message delivery.

The intuitive, interactive GUI provides maximum user control of messaging and real-time status of data transfers and allows warfighters to send and receive interactive text messages and emails. File transfers allow important information such as maps to be received in real-time on the battlefield. The software provides email using Microsoft Outlook, Outlook Express, or other POP3/SMTP compatible email applications. For ease of use, the functional panels for communications status, transmitter queue, chat notes, address book, and email status are user configurable.

In addition to being used with the PDA-184 software application the ACC-188 can also be used to support other tactical data communications and situational awareness applications that were developed in the private sector for military use. The ACC-188 communicates via standard synchronous raw mode communications, and has software drivers available for both Windows and Linux applications allow many users to create their own custom applications.

Figure 3 shows a screenshot of a typical PDA-184 configuration

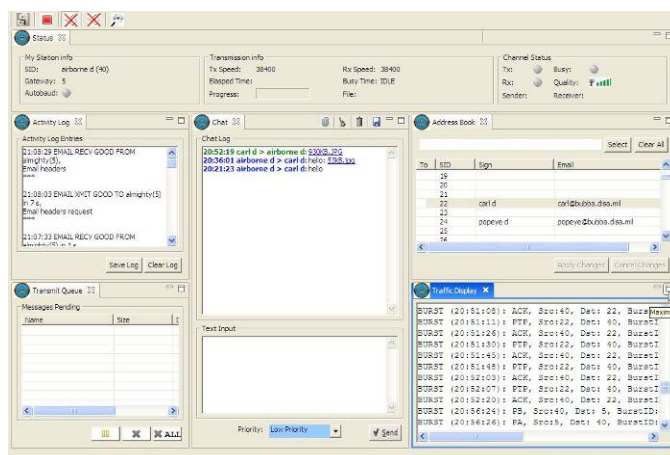

Bridging the Gap to the Tactical Radios of the Future

In the late 1990's, the U. S. military defined a next-generation Software Defined Radio (SDR) system called JTRS or Joint Tactical Radio Systems. A variety of JTRS radios are currently use (and more are under development) ranging from handhells to multi-band, multi-mode, multiple channel radios supporting advanced waveform capabilities and integrated networking features. These software-programmable radios provide much improved voice, data, and video communications built on the Software Communications Architecture (SCA) framework. The ACC-188/PDA-184 solution offers all types of JTRS tactical radios interoperability, regardless of the radio manufacturer.

The ACC-188 USB Synchronous Serial Radio Adapter from Sealevel and the PDA-184 software from DISA provide a tested, cost-effective method for adding IP-based communications and interoperability to existing tactical radios.

About Sealevel

Sealevel Systems, Inc., founded in 1986 and based in Liberty, SC, is an American-owned, small business manufacturer of serial and digital communications products and industrial computers. With over 20 years experience producing American-made products for military, government, and commercial customers, our forte is using in-house engineering skills to create custom adaptations of our COTS product line for military and government projects.

Author



Marc Foster, Director of Government Sales

Marc has over 10 years of experience providing military and industrial users with synchronous and asynchronous serial communications solutions. He earned a BS degree in corporate finance from Clemson University. Contact Marc at marcf@sealevel.com or call +1 864-843-4343.