

C4-104.485+I User Manual



Item Number 3547

SEALEVEL
SYSTEMS INCORPORATED

Table of Contents

INTRODUCTION	1
BEFORE YOU GET STARTED	2
WHAT'S INCLUDED	2
OPTIONAL ITEMS.....	2
CARD SETUP	5
ADDRESS SELECTION	5
PORT ENABLE / DISABLE	5
IRQ SELECTION	6
INTERRUPT MODES	6
CLOCK MODES.....	7
OSCILLATOR VALUE (ALIASING).....	7
BAUD RATES.....	8
PROGRAMMABLE FEATURES	10
LINE TERMINATION	10
RS-485 'ECHO'	10
INSTALLATION & CONFIGURATION	11
SOFTWARE INSTALLATION	11
HARDWARE INSTALLATION.....	11
HARDWARE CONFIGURATION	12
ELECTRICAL SPECIFICATIONS	15
CONNECTOR PINOUTS	15
TECHNICAL SPECIFICATIONS	16
APPENDIX A - TROUBLESHOOTING	17
APPENDIX B - HOW TO GET ASSISTANCE	18
APPENDIX C – ELECTRICAL INTERFACES	19
APPENDIX D – ASYNCHRONOUS COMMUNICATIONS	20
APPENDIX E – SILK SCREEN - 3547	21
APPENDIX F - COMPLIANCE NOTICES	22
FEDERAL COMMUNICATIONS COMMISSION STATEMENT	22
WARRANTY	23

Introduction

The 3547 PC/104 serial interface provides four serial ports with 1,500VDC port-to-port isolation that protect the host system from ground loops and voltage transients that are common in remote installations and industrial environments.

For maximum versatility without opening the PC/104 stack, each port is software configurable for full-duplex (4-Wire) RS-422 or RS-485. Half duplex (2-Wire) RS-485 mode is also supported. The 'auto-enable' circuit automatically handles the RS-485 driver, which eliminates the risk of bus contention and data corruption. With the driver controlled in hardware, the RS-485 ports are treated as standard serial COM ports by the operating system.

Features

- 1,500VDC port-to-port isolation
- Each port is software configurable for 4-wire RS-422/485 or 2-wire RS-485
- 16954 buffered UART with 128-byte FIFOs
- Automatic hardware RS-485 enable/disable
- UART support for 9-bit protocol
- Data rates to 921.6K bps
- Jumpers on each port for suppressing ECHO
- Four 10-pin vertical header connectors
- Extended temperature range available (-40°C - +85°C)



Before You Get Started

What's Included

The 3547 is shipped with the following items. If any of these items is missing or damaged please contact Sealevel for replacement.

- **C4-104.485+1 (Item# 3547)** – PC/104 RS-422, RS-485 (Software Selectable) Isolated Serial Interface
- **Sealevel Software CD** – SeaCOM software and user manual

Optional Items

Depending upon your application, you are likely to find one or more of the following items useful with the 3547. All items can be purchased from our website (<http://www.sealevel.com>) or by calling our sales team at 864-843-4343.

Cables

10-Pin IDC Ribbon Cable to DB9M (Item# CA152)

The CA152 allows connects to the 10-pin header on PC/104 boards and provides a DB9M connector that can be panel mounted in an enclosure. This cable is eight inches in length.



DB9F to DB9M Extension Cable (Item# CA127)

The CA127 allows users to extend a DB9 cable up to six feet. The connectors are pinned one-to-one so the cable is compatible with any device or cable with DB9 connectors.



DB9F (RS-422) to DB25M (RS-530) Cable (Item# CA176)

The CA176 allows users to convert any Sealevel RS-422 DB9 Male asynchronous adapter to an RS-530 DB25 Male pinout. This cable is ten inches in length.



DB9F to DB9F – 207M SMPTE Cable (Item# CA190)

The CA190 connects any Sealevel DB9 RS-422 device to a Sony (or compatible) 207M (SMPTE) 9-pin connector. This cable is 72" in length.



Terminal Blocks

Terminal Block Kit (Item# KT105)

The KT105 terminal block kit breaks out a DB9 connector to 9 screw terminals to simplify field wiring of serial connections including RS-422 and RS-485 networks. The kit includes one DB9 terminal block (Item# TB05) and one DB9M to DB9F 72" extension cable (Item# CA127).



Terminal Block – DB9F to 9 Screw Terminals (Item# TB05)

The TB05 terminal block breaks out a DB9 connector to 9 screw terminals to simplify field wiring of serial connections including RS-422 and RS-485 networks. The TB05 is designed to connect directly to Sealevel DB9 serial cards or any cable with a DB9M connector.



Adapters and Converters

DB9F to RJ45 Modular Adapter (Item# RJ9S8)

The RJ9S8 is a DB9 female to RJ45 adapter. It can be configured without tools, and it is an excellent choice for using available infrastructure wiring.



DB9F (RS-422) to DB9F Converter (Item# DB103)

The DB103 is designed to convert a Sealevel DB9 male RS-422 connector to a DB9 female pinout compatible with AC24AT and AC422AT Opto 22 ISA bus cards.



PC/104 Adapter Kits

PC/104 to CompactFlash Adapter (Item# CF104)

The CF104 allows users to easily add a CompactFlash memory card with an IDE interface to a PC/104 stack. The CF104 includes an adapter board built into the PC/104 form factor. The arrangement of mounting holes at the corners allows the board to be rotated and mounted 180 degrees on the long axis.



PC/104 to 2.5" Hard Drive Adapter (Item# HD104)

The HD104 allows users to easily add an optional 2.5" hard drive with an IDE interface to a PC/104 stack. The HD104 includes an adapter board built into the PC/104 form factor, and offers two different mounting options.



Card Setup

The 3547 contains a single 4 position DIP-Switch (labeled SW1) that provides the address selection for the adapter and a jumper strip (labeled E5) providing the IRQ selection for the adapter.

Address Selection

Each port on the 3547 occupies sixteen consecutive I/O locations. The DIP switch is used to set the base address for the serial ports and the following table shows the addressing options available. If different address options are required, please contact Sealevel Systems Technical Support about a custom PAL option.

SW1-1	SW1-2	SW1-3	Port 1	Port 2	Port 3	Port 4
OFF	OFF	ON	300	310	320	330
OFF	ON	OFF	400	410	420	430
OFF	ON	ON	500	510	520	530
ON	OFF	OFF	600	610	620	630
ON	OFF	ON	1500	1510	1520	1530
ON	ON	OFF	3220	3230	3240	3250
ON	ON	ON	4220	4230	4240	4250

The fourth switch, 'S' on the DIP switch is used to allow a shared interrupt between multiple PC/104 adapters. Reference the Interrupt Modes section on the following page for additional information.

An image and a drawing of the DIP switch (SW1) are shown below.

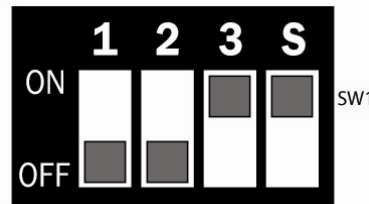
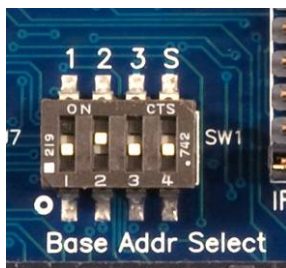

Port Enable / Disable

All four ports on the 3547 can be disabled by setting the switches 1, 2, and 3 on SW1 to the 'Off' position. The ports are enabled when a valid I/O selection is made. If the adapter is disabled, be sure to disable the interrupt request by removing the IRQ jumper from E5.

IRQ Selection

The 3547 has an interrupt selection jumper (labeled E5) for all four of the ports. Be sure to set the interrupt required by your application prior to installation. Consult the manual included with your software application to determine the proper setting.

The jumpers located at E5 are used to select the appropriate interrupt for the adapter. The jumper for the 1K pull-down resistor (labeled 'PD') on E5 connects the resistor to the interrupt line to keep the line from floating. This jumper must be connected when either a single board or multiple boards on different interrupts are in use. In situations where multiple cards are sharing interrupts, only one board in the group should have the PD resistor connected.

An image and a drawing of E5 are included below.

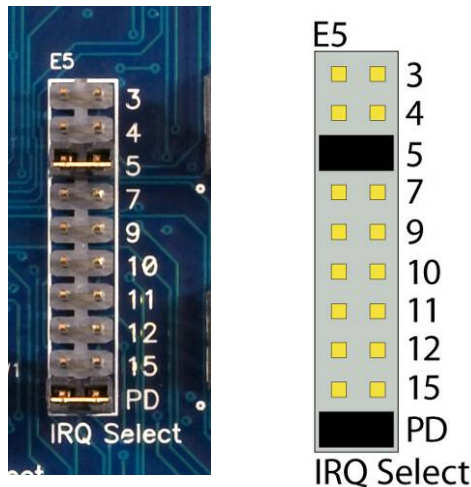

Interrupt Modes

Shared interrupt mode is used to allow more than one PC/104 board to share a single IRQ. The switch position 'S' on DIP switch SW1, when moved to the 'on' position, selects the shared interrupt mode for the adapter. When configuring two or more PC/104 adapters, the following criteria must be met:

- The 'S' switch on DIP switch SW1 should be set to 'on' for each adapter that will share an interrupt.
- The IRQ jumpers (E5) on each adapter need to be set to the same IRQ.
- Each board must be set to a different address. For example, if two boards are used, the addresses might be set as follows:

DIP switch:	1	2	3	S
Board 1:	Off	Off	On	On
Board 2:	Off	On	Off	On

Refer to the Address Selection section for additional information.

- Only one card in the group should have the pull-down (PD) on E5 activated.

The image below shows what the DIP switch and jumper settings would look like for two PC/104 boards installed in the same computer.

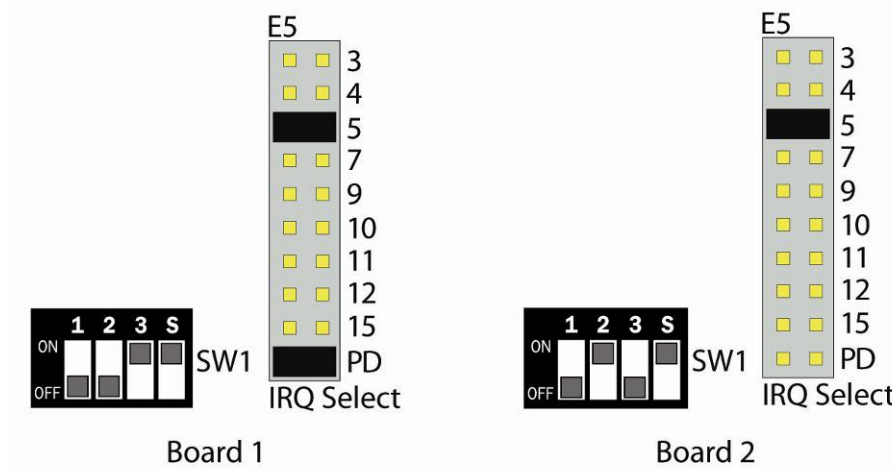

In situations where PC/104 boards do not need to share interrupts, make sure that the switch position 'S' on DIP switch SW1 is moved to the 'off' position. In addition the IRQ jumpers on E5 should be set to different interrupts for each board.

Clock Modes

The 3547 utilizes a 14.7456 MHz oscillator. This is eight times faster than a standard COM: port oscillator, which typically is 1.8432 MHz. This allows the adapter to achieve a maximum data rate of 921.6K bps. The following sections outline the baud rate calculations and instructions for achieving your desired baud rate.

Oscillator Value (Aliasing)

If Windows operating system used, the oscillator value (14.7456 MHz) should be entered into the 'Advanced' tab in the Device Manager. This is usually done automatically when the Sealevel SeaCOM driver is loaded.

If you are using a Windows operating system, the Sealevel SeaCOM driver will typically set the oscillator value automatically. To set the value manually, open the Windows Device Manager and click on 'Ports (COM & LPT).' Locate the port number for your device and right click to select 'Properties.' In the Properties window, open the 'Port Settings' tab and click on the 'Advanced' button. Enter the oscillator value (14.7456).

Note: If using an operating system other than Windows, you may need to manually enter the oscillator value. If you do not do this, all data rates will be eight times the selected rate. For example, if a data rate of 19.2Kbps is selected, the actual data rate will be 153.6Kbps. Refer to Baud Rates section on the following page for appropriate settings and divisors.

Baud Rates

The SeaCOM driver for Windows will automatically set the correct data rate for your card. However, if you are using an operating system other than Windows, the data rate will be eight times the selected rate. You may need to set the data rate manually in order to configure the card to run at the desired rate.

If your operating system does not allow you to manually set the oscillator value on your card, you will need to select a data rate that is eight times less than the desired rate. The table below includes some common data rates.

Note: You can also choose additional baud rates by dividing the baud rate you wish to achieve by eight. The resulting number will be the baud rate you will need to tell your system in order to cause your card to run at the desired rate.

For this Data Rate	Choose this Data Rate
1200 bps	150 bps
2400 bps	300 bps
4800 bps	600 bps
9600 bps	1200 bps
19.2K bps	2400 bps
38.4 K bps	4800 bps
115.2 K bps	14.4K bps
230.4K bps	28.8K bps
460.8K bps	57.6 K bps
921.6K bps	115.2 K bps

In situations where you are communicating with the hardware directly, or using software that requires a divisor, you will need to select a divisor that will cause your card to run at the desired rate. The table below includes some common divisors.

Note: You can also select other divisors by dividing 921.6K by your intended baud rate. The resulting number will be the divisor that you will need to give your system for your card to run at the desired rate.

For this Data Rate	Choose this Divisor
1200 bps	768
2400 bps	384
4800 bps	192
9600 bps	96
19.2K bps	48
38.4K bps	24
57.6K bps	16
115.2K bps	8
230.4K bps	4
460.8K bps	2
921.6K bps	1

Programmable Features

Each of the ports on the 3547 can be individually software configured as an RS-422 or RS-485 interface. Electrical interface selection is handled via the 'Control' port (Base + 15) or via the Sealevel SeaCOM driver interface in Windows Device Manager.

Power up default = 2-wire RS-485 with RTS

D2	D1	D0	Mode
X	X	0	RS-422
0	0	1	RS-485, 4-wire, RTS auto-enable
0	1	1	RS-485, 4-wire, DTR auto-enable
1	0	1	RS-485, 2-wire, RTS auto-enable
1	1	1	RS-485, 2-wire, DTR auto-enable

D0 = RS-422/485; D1 = RTS/DTR auto-enable; D2 = 2-wire/4-wire

Line Termination

Typically, each end of the RS-485 bus must have line-terminating resistors (RS-422 terminates at the receive end only). A 120-ohm resistor is across each RS-422/485 input in addition to a 510-ohm pull-up/pull-down combination that biases the receiver inputs. If multiple 3547 adapters are configured in an RS-485 network, only the boards on each end should have the termination in place. If you have additional questions on how to remove this termination, contact Technical Support at 864-843-4343.

RS-485 'Echo'

The RS-485 'Echo' is the result of connecting the receiver inputs to the transmitter outputs. Each time a character is transmitted; it is also received. This can be beneficial if the software can handle echoing (i.e. using received characters to throttle the transmitter), but it can also confuse the system if the software cannot support echoing.

Echo is controlled on a per-port basis by jumpers E1, E2, E3, and E4. When a jumper is in place, Echo is suppressed. Similarly, Echo can be enabled by removing a jumper from the appropriate port. The image below shows jumper E1 located next to P1.

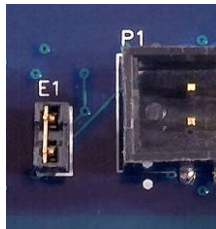

Installation & Configuration

Software Installation

Windows 98/ME/NT/2000/XP/Vista™ Operating Systems



Do not install the adapter in the machine until the software has been fully installed.

1. Start Windows.
2. Insert the Sealevel Software CD in to your CD drive.
3. If 'Auto-Start' is enabled the installation window will automatically appear. Otherwise, navigate to the root directory of your CD drive and double-click the 'autorun.exe' application to launch the installation window.
4. Select 'Install'.
5. Type in your part number (3547) to select your adapter from the listing.
6. The setup file will automatically detect the operating environment and install the proper components.

You are now ready to proceed with installing the 3547 in your system. Refer to the following section, Hardware Installation, for details.

Linux

Refer to the **Linux SerialHOWTO** found on the Sealevel Software CD. This series of files both explains typical Linux serial implementations and informs the user about Linux syntax and preferred practices.

In addition, the software selectable interface settings can be accessed by referencing `D:\software\seacom\Other\Linux\Utilities\3540_Configuration_Utility`.

Hardware Installation



Take extreme care when installing the adapter to avoid damaging the PC/104 connector pins. Be sure to follow proper ESD procedures by grounding yourself and the adapter.

To install the 3547 into your computer, follow the steps below.

1. Turn off PC power and disconnect the power cord.
2. Remove the case cover (if applicable).

3. Mount the hardware using the nylon stand-offs and/or screws provided to ensure a good mechanical connection. Retain any unused mounting hardware for future expansion.
4. Gently insert the adapter noting proper key orientation of the expansion connector on a PC/104 compatible card. The adapter is keyed per the current PC/104 specification to prevent the adapter from being inserted incorrectly.
5. After the adapter is installed, connect up to four I/O cables to the 10-pin headers at Ports 1 through 4. These headers are keyed to prevent cables from being installed incorrectly.

Note: The optional CA152 cable is an eight inch long IDC ribbon cable with a 10-pin connector on one end and a DB9 male connector on the other end. The CA152 can be panel mounted in your enclosure.

6. Proceed with adding additional PC/104 cards (if applicable) and secure with additional standoffs. If this board is at the top of the PC/104 stack, secure the board with #4-40 machine screws.
7. Replace the cover (if applicable).
8. Connect the power cord and power up the machine.

You are now ready to configure the PC/104 adapter to work in your application. Refer to the following section, Hardware Configuration, for details.

Hardware Configuration

1. Run the 'Add Hardware' utility located in the Control Panel. Double click the icon to launch the wizard, and follow the prompts.
 - Windows will first search for plug and play devices. Windows will be unable to locate the board because it is not plug and play.
 - The wizard will ask if you have already installed the hardware, click on 'yes.'
 - When the Installed Hardware List appears, select 'Add a new hardware device' at the bottom of the list.
 - Windows will ask if you want the system to search for additional devices. Select 'I want to install the hardware I manually select from a list' and click on the 'Next' button.
 - Windows will display a list of common hardware types. Select 'Show all devices' and click on 'Next.' The system will compile a thorough list of hardware.
 - Once the list is compiled, locate the left hand column and select 'Sealevel Systems, Inc.' from the list. Next, locate the right hand column and select 'C4-104.485+1: PC-104 4 Port RS-422/485 (3547)' from the list and click 'Next.'

- Windows will show a warning message that the hardware has not passed Windows logo testing. Click on the 'Continue anyway' button.

Note: all applications and drivers have been fully tested to maintain the integrity of your operating system. Clicking on 'Continue anyway' will not harm your system in any way.

- The Completing Add Hardware wizard will appear. At the bottom of the window, click on the link titled 'View or change resources for this hardware (advanced).'
- On the Resources page, click on the 'Set configuration manually' button.

Note: Be sure that the setting you select for the configuration match the settings on your board

Note: This window will show the default settings for the I/O address and one IRQ. Since Windows cannot detect the settings there may be a conflict with another device or the settings shown may be not the settings you wish to use.

- To change the settings choose the appropriate basic configuration number in the 'Setting Based On' field to match the card settings.
- In the Resource Settings box, scroll to the bottom of the list and double click on 'IRQ' to open the Interrupt Request box.
- In the Value field, select the interrupt that the board is set to. This interrupt will be shared by all four ports.
- Click on 'Ok' to close the interrupt request box.
- Click on 'Ok' again to close the Resource Settings box, and click on 'Finish' in the Completing Add Hardware box.
- The computer will prompt you to shut down and reboot the system.

2. Once the hardware has been installed, restart your system.

3. After the system reboots, the Found New Hardware wizard will appear for each port that you are installing (up to four in this case).

- Click on 'Install the software automatically' followed by the 'Next' button.
- The warning message stating that the device has not passed Windows logo testing will appear (this is the same message you saw earlier in the process) and you should click on 'Continue Anyway.'
- Click on 'Finish.' Repeat this process for the remaining ports on the card.

Note: The installation instructions above are best used with Windows XP. If you are using a different version of Windows, and need additional assistance, contact Technical Support at 864-843-4343.

To confirm that the drivers have been successfully installed, you can look in the Device Manager under 'Ports (COM & LPT)' and each of the ports that you installed should be included on the list with their associated COM numbers.

In addition, the software selectable settings can be accessed and changed via the 'Advanced' tab in the device manager. The 'Software Selectable Cards' section allows the electrical interface to be changed between RS-422, RS-485 3-wire, and RS-485 4-wire. For additional information, reference the Programmable Features section of this manual.

Electrical Specifications

The 3547 provides four RS-422/485 software programmable ports from a single PC/104 adapter. The 3547 utilizes the 16954 UART. This chip supports 9-bit protocol and features programmable baud rate, data format, interrupt control and industry leading 128-byte transmit and receive FIFOs.

Connector Pinouts

10-pin Pinout

This board uses a 10-pin 0.1" box header for each of its four ports. This pinout for each port is included below.

Pin #	Signal
1	RX+/Data+
2	NC
3	RX-/Data-
4	NC
5	TX-
6	NC
7	TX+
8	NC
9	GND
10	NC

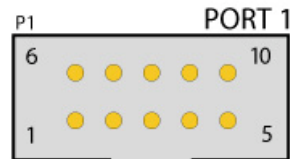

DB9 Pinout

The optional CA152 cable is an eight inch long IDC ribbon cable with a 10-pin connector on one end and a DB9 male connector on the other. This cable provides the standard Sealevel Systems DB9 pinout for RS-422/485. This pinout is shown below.

Pin #	Signal
1	RX+/Data+
2	RX-/Data-
3	TX-
4	TX+
5	GND
6	NC
7	NC
8	NC
9	NC

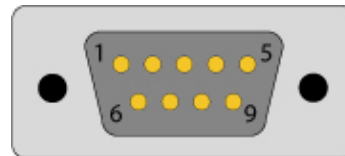

Technical Specifications

Dimensions

Length	Width	Height (top)	Height (bottom)
3.550"	3.775"	0.435"	0.100"
9.017cm	9.589cm	1.105cm	0.254cm

Environmental Specifications

Specification	Operating	Storage
Temperature Range	0°C – 70°C (32°F – 158°F)	-50°C – 105°C (-58°F – 221°F)
Humidity Range	10 to 90% R.H. Non-Condensing	10 to 90% R.H. Non-Condensing

Manufacturing

All Sealevel Systems printed circuit boards are built to UL 94V0 rating and are 100% electrically tested. These printed circuit boards are solder mask over bare copper or solder mask over tin nickel.

Appendix A - Troubleshooting

The adapter should provide years of trouble-free service. However, in the event that device appears to not be functioning incorrectly, the following tips can eliminate most common problems without the need to call Technical Support.

1. Identify all I/O adapters currently installed in your system. This includes your on-board serial ports, controller cards, sound cards etc. The I/O addresses used by these adapters, as well as the IRQ (if any) should be identified.
2. Configure your Sealevel Systems adapter so that there is no conflict with currently installed adapters. No two adapters can occupy the same I/O address. For more information, refer to the Address Selection portion of this manual.
3. Many other adapters do not allow the sharing of IRQs. Try the Sealevel Systems adapter with a unique IRQ.
4. Make sure the adapter is securely installed.
5. For Windows operating systems, the diagnostic tool 'WinSSD' is installed in the SeaCOM folder on the Start Menu during the setup process. First find the ports using the Device Manager, then use 'WinSSD' to verify that the ports are functional.
6. Remember if a "No Echo" mode is selected, a data loopback cannot be accomplished.
7. Always use the Sealevel Systems diagnostic software when troubleshooting a problem. This will eliminate any software issues from the equation.

If these steps do not solve your problem, please call Sealevel Systems' Technical Support, (864) 843-4343. Our technical support is free and available from 8:00 AM to 5:00 PM Eastern Time Monday through Friday. For email support contact support@sealevel.com.

Appendix B – How To Get Assistance

Begin by reading the Troubleshooting Guide in **Appendix A**. This will help solve most common problems.

When calling for technical assistance, please have the device installed and ready to run diagnostics. If possible, have your user manual and current adapter settings ready.

The Sealevel website is an excellent resource. Our homepage is located online at <http://www.sealevel.com>. The most current software updates and user manuals are available via our homepage by clicking on the 'Drivers' or 'Manuals' links located under 'Technical Support.' Manuals and software can also be downloaded from the product page for your device.

The FAQ section of our website answers many common questions. Refer to this helpful resource by visiting <http://www.sealevel.com/faq.asp>.

Technical support is available Monday through Friday from 8:00am to 5:00pm EST and can be reached by phone at +1 (864) 843-4343 or via email at support@sealevel.com.

RETURN AUTHORIZATION MUST BE OBTAINED FROM SEALEVEL SYSTEMS BEFORE RETURNED MERCHANDISE WILL BE ACCEPTED. AUTHORIZATION CAN BE OBTAINED BY CALLING SEALEVEL SYSTEMS AND REQUESTING A RETURN MERCHANDISE AUTHORIZATION (RMA) NUMBER.

Appendix C – Electrical Interfaces

RS-422

The RS-422 specification defines the electrical characteristics of balanced voltage digital interface circuits. RS-422 is a differential interface that defines voltage levels and driver/receiver electrical specifications. On a differential interface, logic levels are defined by the difference in voltage between a pair of outputs or inputs. In contrast, a single ended interface, for example RS-232, defines the logic levels as the difference in voltage between a single signal and a common ground connection. Differential interfaces are typically more immune to noise or voltage spikes that may occur on the communication lines. Differential interfaces also have greater drive capabilities that allow for longer cable lengths. RS-422 is rated up to 10 Megabits per second and can have cabling 4000 feet long. RS-422 also defines driver and receiver electrical characteristics that will allow one driver and up to 32 receivers on the line at once. RS-422 signal levels range from 0 to +5 volts. RS-422 does not define a physical connector.

RS-485

RS-485 is backwardly compatible with RS-422; however, it is optimized for party line or multi-drop applications. The output of the RS-422/485 driver is capable of being Active (enabled) or Tri-State (disabled). This capability allows multiple ports to be connected in a multi-drop bus and selectively polled. RS-485 allows cable lengths up to 4000 feet and data rates up to 10 Megabits per second. The signal levels for RS-485 are the same as those defined by RS-422. RS-485 has electrical characteristics that allow for 32 drivers and 32 receivers to be connected to one line. This interface is ideal for multi-drop or network environments. RS-485 tri-state driver (not dual-state) will allow the electrical presence of the driver to be removed from the line. Only one driver may be active at a time and the other driver(s) must be tri-stated. RS-485 can be cabled in two ways, two wire and four wire mode. Two-wire mode does not allow for full duplex communication, and requires that data be transferred in only one direction at a time. For half-duplex operation, the two transmit pins should be connected to the two receive pins (Tx+ to Rx+ and Tx- to Rx-). Four wire mode allows full duplex data transfers. RS-485 does not define a connector pinout or a set of modem control signals. RS-485 does not define a physical connector.

Appendix D – Asynchronous Communications

Serial data communications implies that individual bits of a character are transmitted consecutively to a receiver that assembles the bits back into a character. Data rate, error checking, handshaking, and character framing (start/stop bits) are pre-defined and must correspond at both the transmitting and receiving ends.

Asynchronous communications is the standard means of serial data communication for PC compatible and PS/2 computers. The original PC was equipped with a communication or COM: port that was designed around an 8250 Universal Asynchronous Receiver Transmitter (UART). This device allows asynchronous serial data to be transferred through a simple and straightforward programming interface. A starting bit followed by a pre-defined number of data bits (5, 6, 7, or 8) defines character boundaries for asynchronous communications. The end of the character is defined by the transmission of a pre-defined number of stop bits (usually 1, 1.5 or 2). An extra bit used for error detection is often appended before the stop bits. The diagram below demonstrates asynchronous communication bits.

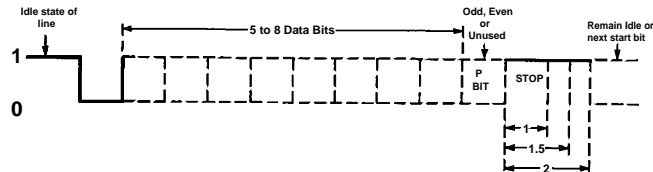

This special bit is called the parity bit. Parity is a simple method of determining if a data bit has been lost or corrupted during transmission. There are several methods for implementing a parity check to guard against data corruption. Common methods are called (E)ven Parity or (O)dd Parity. Sometimes parity is not used to detect errors on the data stream. This is referred to as (N)o parity. Because each bit in asynchronous communications is sent consecutively, it is easy to generalize asynchronous communications by stating that each character is wrapped (framed) by pre-defined bits to mark the beginning and end of the serial transmission of the character. The data rate and communication parameters for asynchronous communications have to be the same at both the transmitting and receiving ends. The communication parameters are baud rate, parity, number of data bits per character, and stop bits (i.e. 9600,N,8,1).

Appendix E – Silk Screen – 3547

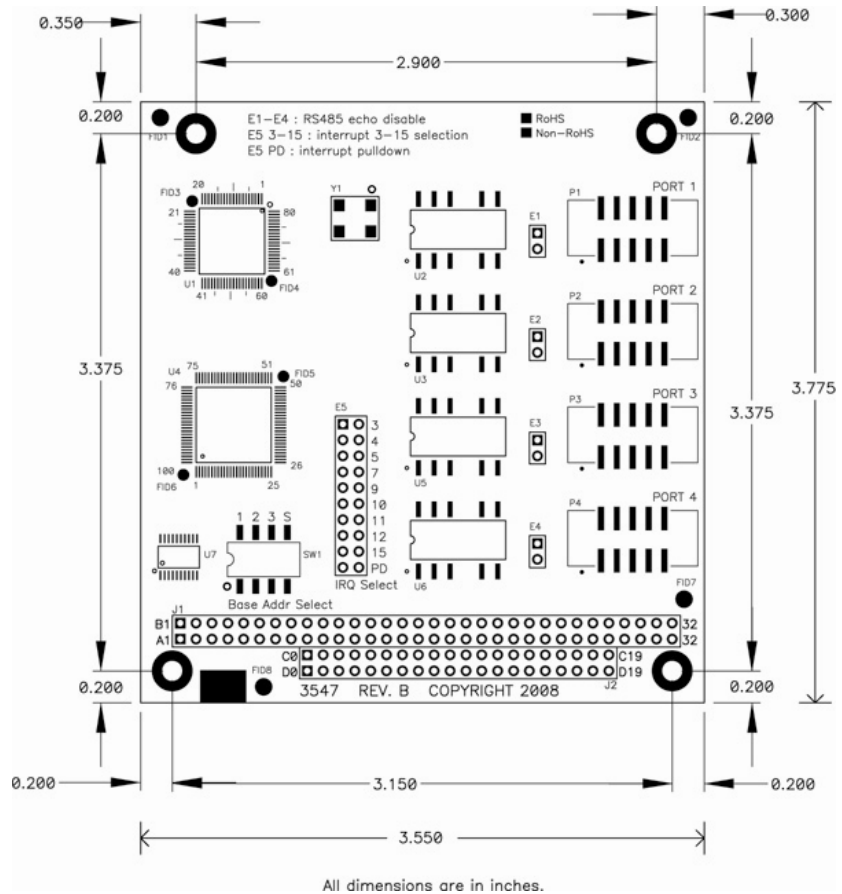

Appendix F - Compliance Notices

Federal Communications Commission Statement

FCC - This equipment has been tested and found to comply with the limits for Class A digital device, pursuant to Part 15 of the FCC Rules. These limits are designed to provide reasonable protection against harmful interference when the equipment is operated in a commercial environment. This equipment generates, uses, and can radiate radio frequency energy and, if not installed and used in accordance with the instruction manual, may cause harmful interference to radio communications. Operation of this equipment in a residential area is likely to cause harmful interference in such case the user will be required to correct the interference at the users expense.

EMC Directive Statement



Products bearing the CE Label fulfill the requirements of the EMC directive (89/336/EEC) and of the low-voltage directive (73/23/EEC) issued by the European Commission.

To obey these directives, the following European standards must be met:

EN55022 Class A - “Limits and methods of measurement of radio interference characteristics of information technology equipment”

EN55024 – “Information technology equipment Immunity characteristics Limits and methods of measurement”.

EN60950 (IEC950) - “Safety of information technology equipment, including electrical business equipment”

Warning

This is a Class A Product. In a domestic environment, this product may cause radio interference in which case the user may be required to take adequate measures to prevent or correct the interference.

Always use cabling provided with this product if possible. If no cable is provided or if an alternate cable is required, use high quality shielded cabling to maintain compliance with FCC/EMC directives.

Warranty



Sealevel's commitment to providing the best I/O solutions is reflected in the Lifetime Warranty that is standard on all Sealevel manufactured products. We are able to offer this warranty due to our control of manufacturing quality and the historically high reliability of our products in the field. Sealevel products are designed and manufactured at its Liberty, South Carolina facility, allowing direct control over product development, production, burn-in and testing.

Sealevel Systems, Inc. (hereafter "Sealevel") warrants that the Product shall conform to and perform in accordance with published technical specifications and shall be free of defects in materials and workmanship for life. In the event of failure, Sealevel will repair or replace the product at Sealevel's sole discretion. Failures resulting from misapplication or misuse of the Product, failure to adhere to any specifications or instructions, or failure resulting from neglect or abuse are not covered under this warranty.

Warranty service is obtained by delivering the Product to Sealevel and providing proof of purchase. **Return authorization must be obtained from Sealevel Systems before returned merchandise will be accepted. Authorization is obtained by calling Sealevel Systems and requesting a Return Merchandise Authorization (RMA) number.** The Customer agrees to insure the Product or assume the risk of loss or damage in transit, to prepay shipping charges to Sealevel, and to use the original shipping container or equivalent. Warranty is valid only for original purchaser and is not transferable.

Sealevel Systems assumes no liability for any damages, lost profits, lost savings or any other incidental or consequential damage resulting from the use, misuse of, or inability to use this product. Sealevel Systems will not be liable for any claim made by any other related party.

This warranty applies to Sealevel manufactured Product. Product purchased through Sealevel but manufactured by a third party will retain the original manufacturer's warranty.

**Sealevel Systems, Incorporated
2779 Greenville Highway
P.O. Box 830
Liberty, SC 29657 USA
(864) 843-4343 FAX: (864) 843-3067
www.sealevel.com
email: support@sealevel.com**

Technical Support is available Monday - Friday from 8 a.m. to 5 p.m. Eastern time

Trademarks

Sealevel Systems, Incorporated acknowledges that all trademarks referenced in this manual are the service mark, trademark, or registered trademark of the respective company.