

SeaLINK+ 4/232.RJ User Manual



Part Number 2404



Table of Contents

INTRODUCTION.....	1
SEALEVEL USB SERIAL I/O PRODUCT FAMILY.....	2
BEFORE YOU GET STARTED.....	3
WHAT'S INCLUDED.....	3
OPTIONAL ITEMS.....	3
SOFTWARE INSTALLATION INSTRUCTIONS	4
WINDOWS 98/ME/2000/XP/VISTA™ OPERATING SYSTEMS	4
PHYSICAL INSTALLATION	5
TECHNICAL DESCRIPTION.....	6
CONNECTOR PIN ASSIGNMENTS (RJ45).....	6
OPTIONAL DC POWER ON PIN 5.....	7
OPTIONAL RJ45 TO DB9 RS-232 ADAPTER.....	7
ELECTRICAL CHARACTERISTICS	8
FEATURES	8
SPECIFICATIONS.....	8
APPENDIX A - TROUBLESHOOTING	9
APPENDIX B - HOW TO GET ASSISTANCE	10
APPENDIX C – ELECTRICAL INTERFACE.....	11
RS-232	11
APPENDIX D - ASYNCHRONOUS COMMUNICATIONS	12
APPENDIX E – SILK SCREEN – 2404 PCB	13
APPENDIX F - COMPLIANCE NOTICES	14
FEDERAL COMMUNICATIONS COMMISSION STATEMENT	14
WARRANTY.....	15

Introduction

The Sealevel Systems SeaLINK+4/232.RJ (Item# 2404) is a USB device that equips the PC with four RS-232 Asynchronous serial ports that support TX, RX, RTS, and CTS and data rates up to 115.2K baud. The 2404 is housed in an attractive plastic enclosure with a high-retention USB type "B" connector that prevents accidental disconnection of the included USB cable.

The 2404 is USB bus powered, so no external power supply is required. For conveniently powering serial peripherals, ordering options allow an external power source up to be connected to a DC jack on the rear of the unit. The supplied power is fused and connected to pin 5 on each of the four RJ45 connectors.

The SeaLINK+4/232.RJ is designed to be used with a variety of Operating Systems including Windows 98/ME/2000/XP. The SeaCOM API (Application Programmer Interface) included on CD with the SeaLINK+4/232.RJ provides a variety of useful high-level function calls implemented as a Windows dynamic link library (DLL). In addition to the API, SeaCOM includes sample code and utilities to simplify software development.

Sealevel USB Serial I/O Product Family

Model #	Part #	Description
SeaLINK+232	2101	- 1-Port RS-232 DB25
SeaLINK+232	2105	- 1-Port RS-232 DB9
SeaLINK+485	2102	- 1-Port RS-422/485/530 DB25
SeaLINK+232I	2103	- 1-Port Isolated RS-232 DB25
SeaLINK+485I	2104	- 1-Port Isolated RS-422/485/530 DB25
SeaLINK+422	2106	- 1-Port RS-422 Cable DB9
SeaLINK+232.PC	2108	- 1-Port Embedded RS-232 Box Header
SeaLINK+2/232	2201	- 2-Port RS-232 DB9
SeaLINK+2/485	2202	- 2-Port RS-422/485 DB9
SeaLINK+2	2203	- 2-Port RS-232/422/485 DB9
SeaLINK+2/232.PC	2208	- 2-Port Embedded RS-232 Box Header
SeaLINK+4/232	2401	- 4-Port RS-232 DB9
SeaLINK+4/485	2402	- 4-Port RS-422/485 DB9
SeaLINK+4	2403	- 4-Port RS-232/422/485 DB9
SeaLINK+4/232.RJ	2404	- 4-Port RS-232 RJ45
SeaLINK+4.VC	2407	- 4-Port RS-232/485 VersaCom
SeaLINK+8/232	2801	- 8-Port RS-232 DB9
SeaLINK+8/485	2802	- 8-Port RS-422/485 DB9
SeaLINK+8	2803	- 8-Port RS-232/422/485 DB9
SeaLINK+8/232.RJ	2804	- 8-Port RS-232 RJ45
SeaLINK+8.VC	2807	- 8-Port RS-232/485 VersaCom
SeaLINK+16/232.RJ	2161	- 16-Port RS-232 RJ45
SeaLINK+16.VC	2167	- 16-Port RS-232/485 VersaCom

Before You Get Started

What's Included

The SeaLINK+4/232.RJ is shipped with the following items. If any of these items is missing or damaged please contact Sealevel for replacement.

- **Item# 2404 – SeaLINK+4/232.RJ USB 8-Port Serial Device**
- **Item# CA179 – 72” USB ‘A’ to ‘B’ Device Cable**
- **Item# LB116 – RS-232 RJ45 Serial Loopback**
- **Sealevel SeaCOM Software CD**

Optional Items

Depending upon your application, you are likely to find one or more of the following items useful for interfacing the SeaLINK+4/232.RJ. All items can be purchased from our website (<http://www.sealevel.com>) or by calling 864-843-4343.

- **DB9 Male to RJ45 Modular Adapter (Item# RJ9P-232)**
Preconfigured for use with the SeaLINK+4/232.RJ, this modular adapter converts the RJ45 RS-232 pinout from the SeaLINK+4/232.RJ to a DB9 male RS-232 serial port. Standard CAT5 patch cables can be used to extend the serial port up to 50 feet away from the SeaLINK+4/232.RJ.
- **DB25 Male to RJ45 Modular Adapter (Item# RJ25P-232)**
Preconfigured for use with the SeaLINK+4/232.RJ, this modular adapter converts the RJ45 RS-232 pinout from the SeaLINK+4/232.RJ to a DB25 male RS-232 serial port. Standard CAT5 patch cables can be used to extend the serial port up to 50 feet away from the SeaLINK+4/232.RJ.
- **DB9 Male to RJ45 Modular Adapter (Item# RJ9P8)**
The RJ9P8 includes an RJ45 connector and converts it to a DB9 Male connector, which allows the use of standard twisted pair cabling. The RJ9P8 ships unassembled and can be configured for virtually any pin out.
- **DB25 Male to RJ45 Modular Adapter (Item# RJ25P8)**
The RJ25P8 includes an RJ45 connector and converts it to a DB25 Male connector, which allows the use of standard twisted pair cabling. The RJ25P8 ships unassembled and can be configured for virtually any pin out.
- **USB ‘A’ to ‘A’ Extension Cable, 3 Meters in Length (Item# CA214)**
The CA214 is a fully rated USB extension cable that allows adding 3 meters (USB maximum of 5 meters) to any existing USB cable. The cable has a type ‘A’ male connector on one end and a type ‘A’ female connector on the other end.
- **RJ45 Patch Cable, 7’ in Length (Item# CA246)**
Standard 7’ CAT5 patch cable with one-to-one pinout.
- **RJ45 Patch Cable, 10’ in Length (Item# CA247)**
Standard 10’ CAT5 patch cable with one-to-one pinout.

Software Installation Instructions

Windows 98/ME/2000/XP/Vista™ Operating Systems

Do not connect the device to a USB port until the software is installed.

1. Start Windows.
2. Insert the Sealevel Software CD in to your CD drive.
3. If 'Auto-Start' is enabled the installation window will automatically appear. Otherwise, navigate to the root directory of your CD drive and double-click the 'autorun.exe' application to launch the installation window.
4. Select 'Install Software'.
5. Select the Part Number for your device from the listing.
6. The setup file will automatically detect the operating environment and install the proper components. Follow the information presented on the installation screens that follow.
7. A screen may appear with the declaration: "The publisher cannot be determined due to the problems below: Authenticode signature not found." Please select the 'Yes' button and proceed with the installation. This declaration simply means that the Operating System is not aware of the driver being loaded. It will not cause any harm to your system.
8. During setup, you may specify installation directories and other preferred configurations. This program also adds entries to the system registry that are necessary for specifying the operating parameters for each driver. An uninstall option is included to remove the driver and all registry/INI file entries from your system.
9. Proceed with the physical installation of your SeaLINK USB serial adapter.

NOTE:



Windows NT is not USB aware and thus cannot support this device.

Physical Installation

The SeaLINK+4/232.RJ can be connected to any spare USB port.

Do not connect the device to a USB port until the software has been installed.

1. Connect the SeaLINK+4/232.RJ to a USB port with the supplied CA179 USB device cable.
2. The software drivers installed during setup will automatically recognize and configure the device.
3. You should see one or more “New Hardware Found” windows, indicating the actual device being created.
4. **NOTE:** The installation will repeat twice for each COM port (a total of 8 times on the SeaLINK+4/232.RJ). This is a limitation in the way Windows installs external serial devices.
5. Next, view your system’s Device Manager.
6. You should have new COM: ports in the Ports (COM & LPT) Device Class indicating the installation was successful.
7. You can access your new COM: port by using the assigned COM: identifier. This assignment will vary from system to system.
8. To verify operation use Sealevel Systems supplied WinSSD diagnostic utility. WinSSD can be found in the Start, Programs group.

The SeaLINK+4/232.RJ is now ready for use.

Technical Description

The SeaLINK+4/232.RJ utilizes four USB UARTs. These chips feature programmable baud rate, data format, 128 byte Dual Port TX Buffer, and 384 byte Dual Port RX Buffer. The transceivers support data rates up to 921.6K bps.

Connector Pin Assignments (RJ45)

Name	Pin #	Mode
NC No Connect	1	
RTS Request To Send	2	Output
TX Transmit Data	3	Output
GND Ground	4	
NC No Connect	5	
RX Receive Data	6	Input
CTS Clear To Send	7	Input
NC No Connect	8	

Note: DCD, DSR, and RI are inputs that are not brought out on the RJ45 connector. DSR and DCD are biased active and RI is biased inactive.

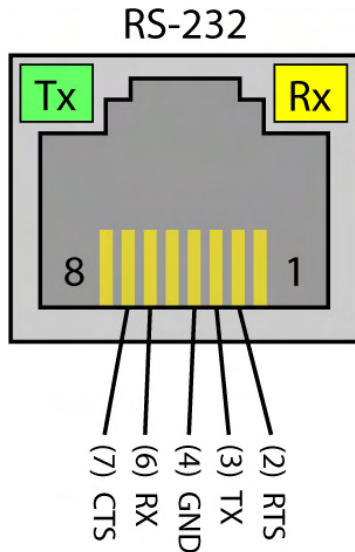

Optional DC Power on Pin 5

The 2404 is USB bus powered, so no external power supply is required. For conveniently powering serial peripherals, ordering options allow an external power source up to be connected to a DC jack on the rear of the unit. The supplied power is connected to pin 5 on each of the four RJ45 connectors. Each serial port utilizes an auto-resetting fuse rated at 500mA. Ordering options are shown below:

- **Item# 2404-DC05**
Configured for 5VDC input power using a 2.1mm DC jack
- **Item# 2404-DC12**
Configured for 12VDC input power using a 1.3mm DC jack
- **Item# 2404-DC24**
Configured for 24VDC input power using a 1.3mm DC jack

Optional RJ45 to DB9 RS-232 Adapter

Preconfigured for use with Sealevel USB RJ45-enabled serial adapters, the RJ45 to DB9 modular adapter (item# RJ9P-232) converts the RJ45 RS-232 pin out to a DB9 male RS-232 serial port. Standard CAT5 patch cables can be used to extend the serial port up to 50 feet away from the RJ45 port. The pin out for the RJ9P-232 is shown below.

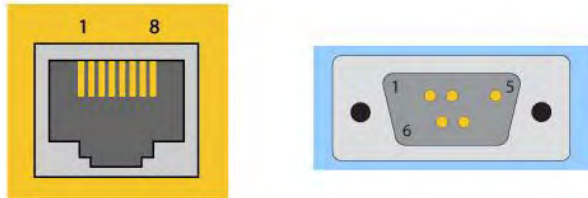

RJ45	Signal	DB-9M
2	RTS	7
3	TD	3
4	GND	5
6	RD	2
7	CTS	8

Electrical Characteristics

Features

- Provides four RJ45 serial ports with status LEDs
- Housed in rugged, attractive plastic enclosure
- Integrates transmit and receive LED indicators on each port
- High-retention USB type “B” connector prevents accidental disconnection of USB cable
- Powered by USB connection

Specifications

Temperature Range

- Operating: $-0^{\circ} - +70^{\circ}\text{C}$
- Storage: $-50^{\circ} - +105^{\circ}\text{C}$

Power Requirements

- +5VDC @ 300mA

Physical Dimensions

Length	Width	Height
9.2”	5.3”	1.7”
23.37 cm	13.46 cm	4.32 cm

Manufacturing

All Sealevel Systems Printed Circuit boards are built to UL 94V0 rating and are 100% electrically tested. These printed circuit boards are solder mask over bare copper or solder mask over tin nickel.

Appendix A - Troubleshooting

Sealevel Software is supplied with the Sealevel Systems adapter and may be used in the troubleshooting procedures. Using this software and following these simple steps can eliminate most common problems without the need to call Technical Support.

1. If your adapter isn't working, first check to make sure that USB support is enabled in the System BIOS and it is functioning properly in the operating system. This can be done by using either the Windows 98/ME or Windows 2000 Device Manager.
2. Ensure that the Sealevel Systems software has been installed on the machine so that the necessary files are in place to complete the installation.
3. When the SeaLINK+4/232.RJ is configured properly, Sealevel's WinSSD utility and a loopback plug can be used to check communications. You can make a simple Loopback in the field by connecting the TX and RX pins. If you decide to test the Modem Control Signals, a full pin loopback plug will be required. Details on loopback plugs are included within WinSSD. Contact Sealevel Systems if you need further assistance.
4. When testing the SeaLINK+4/232.RJ in loopback mode, you should see both the TD and RD echoed as data on the screen. The loopback test first transmits a HEX pattern, 55AA, and then an ASCII string of data. If this test passes, then the SeaLINK+4/232.RJ is ready for use in your application.
5. Always use the Sealevel Systems diagnostic software when troubleshooting a problem. This will eliminate any software issues from the equation.

If these steps do not solve your problem, please call Sealevel Systems' Technical Support, (864) 843-4343. Our technical support is free and available from 8:00 AM to 5:00 PM Eastern Time Monday through Friday. For email support contact support@sealevel.com.

Appendix B – How To Get Assistance

Begin by reading through the Trouble Shooting Guide in Appendix A. If assistance is still needed please see below.

When calling for technical assistance, please have your user manual and current adapter settings. If possible, please have the adapter installed in a computer ready to run diagnostics.

Sealevel Systems provides an FAQ section on its web site. Please refer to this to answer many common questions. This section can be found at <http://www.sealevel.com/faq.asp>

Sealevel Systems maintains a Home page on the Internet. Our home page address is <http://www.sealevel.com>. The latest software updates, and newest manuals are available via our FTP site that can be accessed from our home page.

Technical support is available Monday to Friday from 8:00 AM to 5:00 PM eastern time. Technical support can be reached at (864) 843-4343.

RETURN AUTHORIZATION MUST BE OBTAINED FROM SEALEVEL SYSTEMS BEFORE RETURNED MERCHANDISE WILL BE ACCEPTED. AUTHORIZATION CAN BE OBTAINED BY CALLING SEALEVEL SYSTEMS AND REQUESTING A RETURN MERCHANDISE AUTHORIZATION (RMA) NUMBER.

Appendix C – Electrical Interface

RS-232

Quite possibly the most widely used communication standard is RS-232. This implementation has been defined and revised several times and is often referred to as RS-232 or EIA/TIA-232. The IBM PC computer defined the RS-232 port on a 9 pin D sub connector and subsequently the EIA/TIA approved this implementation as the EIA/TIA-574 standard. This standard is defined as the *9-Position Non-Synchronous Interface between Data Terminal Equipment and Data Circuit-Terminating Equipment Employing Serial Binary Data Interchange*. Both implementations are in wide spread use and will be referred to as RS-232 in this document. RS-232 is capable of operating at data rates up to 20 Kbps at distances less than 50 ft. The absolute maximum data rate may vary due to line conditions and cable lengths. RS-232 is a single ended or unbalanced interface, meaning that a single electrical signal is compared to a common signal (ground) to determine binary logic states. The RS-232 and the EIA/TIA-574 specification define two types of interface circuits, Data Terminal Equipment (DTE) and Data Circuit-Terminating Equipment (DCE). The SeaLINK+4/232.RJ is a DTE device.

Appendix D - Asynchronous Communications

Serial data communications implies that individual bits of a character are transmitted consecutively to a receiver that assembles the bits back into a character. Data rate, error checking, handshaking, and character framing (start/stop bits) are pre-defined and must correspond at both the transmitting and receiving ends.

Asynchronous communications is the standard means of serial data communication for PC compatibles and PS/2 computers. The original PC was equipped with a communication or COM: port that was designed around an 8250 Universal Asynchronous Receiver Transmitter (UART). This device allows asynchronous serial data to be transferred through a simple and straightforward programming interface. A starting bit followed by a pre-defined number of data bits (5, 6, 7, or 8) defines character boundaries for asynchronous communications. The end of the character is defined by the transmission of a pre-defined number of stop bits (usually 1, 1.5 or 2). An extra bit used for error detection is often appended before the stop bits.

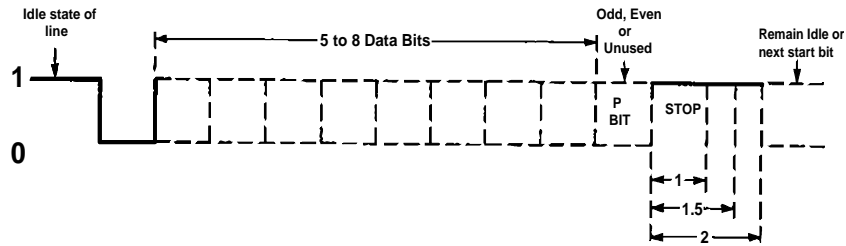

This special bit is called the parity bit. Parity is a simple method of determining if a data bit has been lost or corrupted during transmission. There are several methods for implementing a parity check to guard against data corruption. Common methods are called (E)ven Parity or (O)dd Parity. Sometimes parity is not used to detect errors on the data stream. This is referred to as (N)o parity. Because each bit in asynchronous communications is sent consecutively, it is easy to generalize asynchronous communications by stating that each character is wrapped (framed) by pre-defined bits to mark the beginning and end of the serial transmission of the character. The data rate and communication parameters for asynchronous communications have to be the same at both the transmitting and receiving ends. The communication parameters are baud rate, parity, number of data bits per character, and stop bits (i.e. 9600, N, 8, 1).

Appendix E – Silk Screen – 2404 PCB

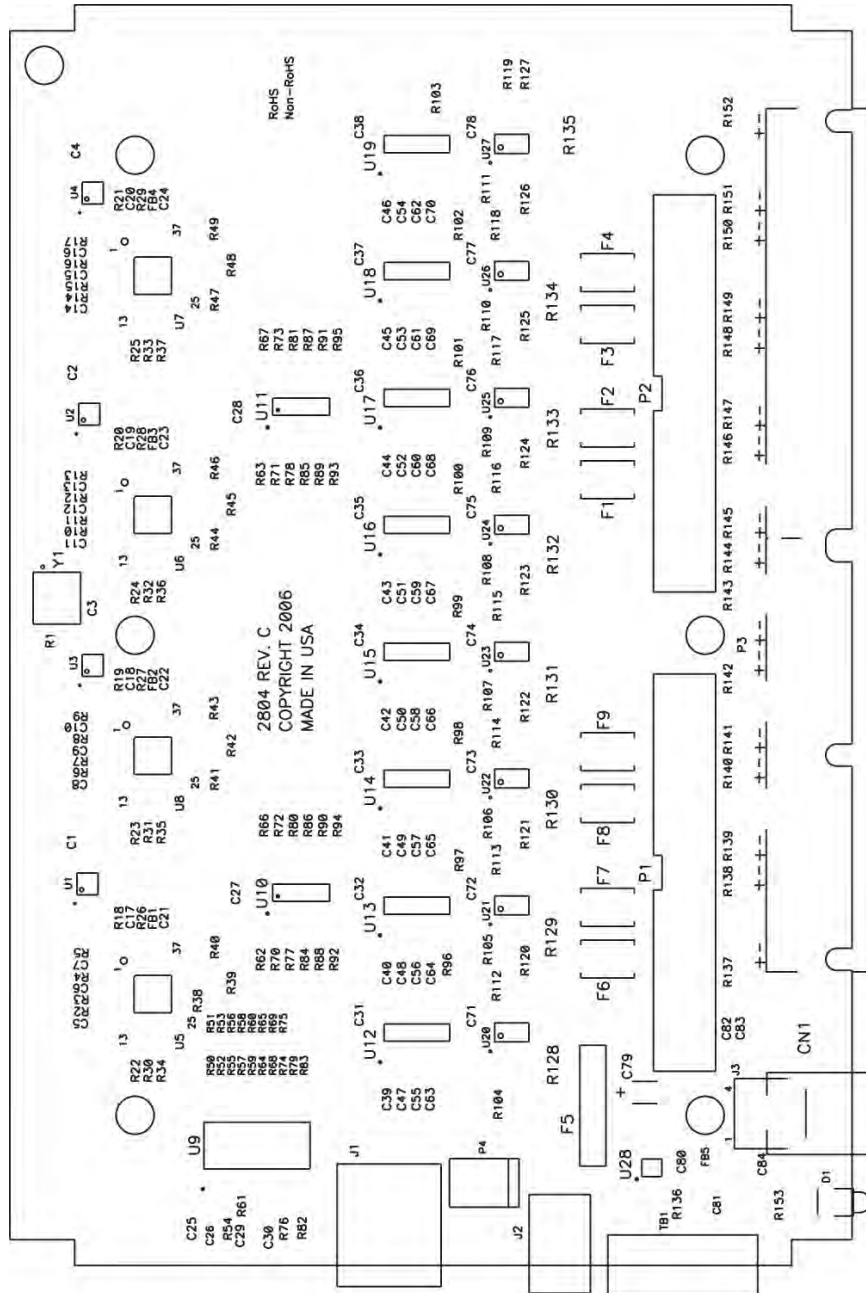

Appendix F - Compliance Notices

Federal Communications Commission Statement

FCC - This equipment has been tested and found to comply with the limits for Class A digital device, pursuant to Part 15 of the FCC Rules. These limits are designed to provide reasonable protection against harmful interference when the equipment is operated in a commercial environment. This equipment generates, uses, and can radiate radio frequency energy and, if not installed and used in accordance with the instruction manual, may cause harmful interference to radio communications. Operation of this equipment in a residential area is likely to cause harmful interference in such case the user will be required to correct the interference at the users expense.

EMC Directive Statement



Products bearing the CE Label fulfill the requirements of the EMC directive (89/336/EEC) and of the low-voltage directive (73/23/EEC) issued by the European Commission.

To obey these directives, the following European standards must be met:

EN55022 Class A - “Limits and methods of measurement of radio interference characteristics of information technology equipment”

EN55024 – “Information technology equipment Immunity characteristics Limits and methods of measurement”.

EN60950 (IEC950) - “Safety of information technology equipment, including electrical business equipment”

Warning

This is a Class A Product. In a domestic environment, this product may cause radio interference in which case the user may be required to take adequate measures to prevent or correct the interference.

Always use cabling provided with this product if possible. If no cable is provided or if an alternate cable is required, use high quality shielded cabling to maintain compliance with FCC/EMC directives.

Warranty



Sealevel's commitment to providing the best I/O solutions is reflected in the Lifetime Warranty that is standard on all Sealevel manufactured products. We are able to offer this warranty due to our control of manufacturing quality and the historically high reliability of our products in the field. Sealevel products are designed and manufactured at its Liberty, South Carolina facility, allowing direct control over product development, production, burn-in and testing.

Sealevel Systems, Inc. (hereafter "Sealevel") warrants that the Product shall conform to and perform in accordance with published technical specifications and shall be free of defects in materials and workmanship for life. In the event of failure, Sealevel will repair or replace the product at Sealevel's sole discretion. Failures resulting from misapplication or misuse of the Product, failure to adhere to any specifications or instructions, or failure resulting from neglect or abuse are not covered under this warranty.

Warranty service is obtained by delivering the Product to Sealevel and providing proof of purchase. **Return authorization must be obtained from Sealevel Systems before returned merchandise will be accepted. Authorization is obtained by calling Sealevel Systems and requesting a Return Merchandise Authorization (RMA) number.** The Customer agrees to insure the Product or assume the risk of loss or damage in transit, to prepay shipping charges to Sealevel, and to use the original shipping container or equivalent. Warranty is valid only for original purchaser and is not transferable.

Sealevel Systems assumes no liability for any damages, lost profits, lost savings or any other incidental or consequential damage resulting from the use, misuse of, or inability to use this product. Sealevel Systems will not be liable for any claim made by any other related party.

This warranty applies to Sealevel manufactured Product. Product purchased through Sealevel but manufactured by a third party will retain the original manufacturer's warranty.

**Sealevel Systems, Incorporated
2779 Greenville Highway
P.O. Box 830
Liberty, SC 29657 USA
(864) 843-4343 FAX: (864) 843-3067
www.sealevel.com
email: support@sealevel.com**

Technical Support is available Monday - Friday from 8 a.m. to 5 p.m. Eastern time

Trademarks

Sealevel Systems, Incorporated acknowledges that all trademarks referenced in this manual are the service mark, trademark, or registered trademark of the respective company.