

SEALEVEL[®]

SYSTEMS INCORPORATED

ISO COMM2.PCI[™]

USER MANUAL

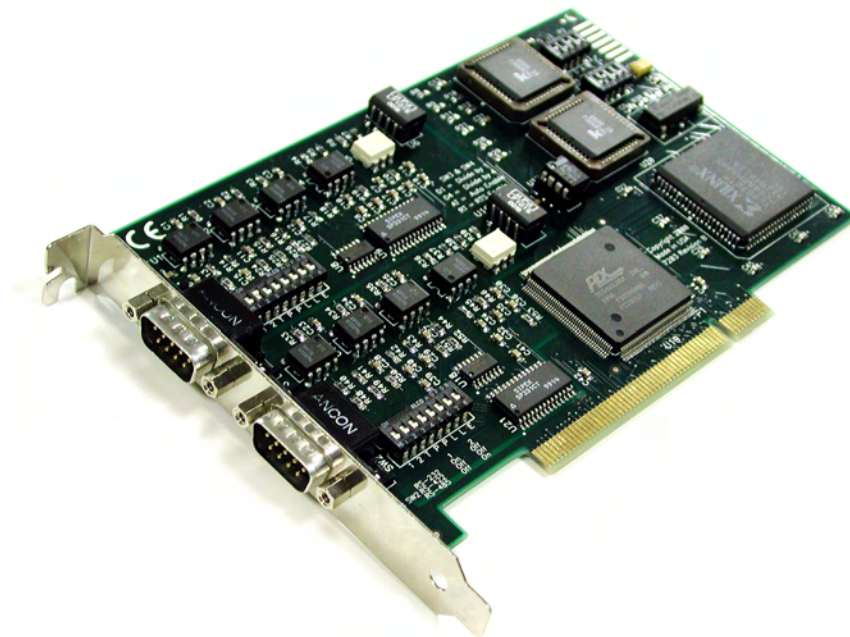

Part # 7203

Sealevel Systems, Inc
P.O. Box 830
Liberty, SC 29657 USA

Phone: (864) 843-4343
FAX: (864) 843-3067
www.sealevel.com

Contents

INTRODUCTION	1
OVERVIEW.....	1
WHAT'S INCLUDED.....	1
FACTORY DEFAULT SETTINGS	1
CARD SETUP	2
ELECTRICAL INTERFACE SELECTION.....	2
LINE TERMINATION	3
RS-485 ENABLE MODES	4
RS-485 ENABLE MODES	4
CLOCK MODES	5
BAUD RATES AND DIVISORS FOR THE 'DIV1' MODE	6
INSTALLATION	7
OPERATING SYSTEM INSTALLATION	7
For Windows Users.....	7
Other Operating Systems	7
SYSTEM INSTALLATION	7
TECHNICAL DESCRIPTION	8
CONNECTOR PIN ASSIGNMENTS.....	8
RS-232	8
RS-422/485	8
SPECIFICATIONS	9
ENVIRONMENTAL SPECIFICATIONS	9
MANUFACTURING.....	9
POWER CONSUMPTION	9
MEAN TIME BETWEEN FAILURES (MTBF)	9
PHYSICAL DIMENSIONS.....	9
APPENDIX A - TROUBLESHOOTING	10
APPENDIX B - HOW TO GET ASSISTANCE	11
APPENDIX C - ELECTRICAL INTERFACE	12
RS-232	12
RS-422	12
RS-485	13
APPENDIX D - GROUND LOOP PHENOMENON	14
WHAT IS GROUND LOOP?	14
CABLING RECOMMENDATIONS	14

APPENDIX E - ASYNCHRONOUS COMMUNICATIONS	15
APPENDIX F - SILK-SCREEN	16
APPENDIX G - COMPLIANCE NOTICES	17
FEDERAL COMMUNICATIONS COMMISSION STATEMENT.....	17
EMC DIRECTIVE STATEMENT	17
WARRANTY.....	18

Figures

Figure 1- RS-232	2
Figure 2 - RS-422	2
Figure 3 - RS-485, 4-Wire with Echo	2
Figure 4 - RS-485 2-Wire with Echo	2
Figure 5 - RS-485, 2-wire without Echo	3
Figure 6 - RS-485 Enable modes	4
Figure 7 - Clocking Modes	5
Figure 8 – ISO COMM +2 cabling example	14
Figure 9 - Asynchronous Communications Bit Diagram	15

© Sealevel Systems, Inc.
SL9060 Revision 7/2006

Sealevel Systems, Incorporated. All rights reserved.

Introduction

Overview

The Sealevel Systems **ULTRA COMM+2I.PCI** is a two channel isolated PCI Bus serial I/O adapter for the PC and compatibles. Utilizing the Exar 16C850 UART with its industry leading 128 byte FIFOs, it provides two field selectable RS-232/422/485 serial ports supporting data rates up to 460.8K bps (RS-422/485).

Configure both ports as RS-232 for standard serial COM: port requirements. Choose the RS-422 mode for long distance device connections up to 5000ft. where noise immunity and high data integrity are essential. Select RS-485 and capture data from multiple peripherals in a RS-485 multidrop network. Up to 31 RS-485 devices can be connected to each port to automate your data collection. You can even mix the ports in any of the interface combinations to provide maximum flexibility to your application. *Optional Terminal Block adapters are available to simplify field-wiring connections.*

In both RS-232 and RS-422 modes, the card works seamlessly with the standard operating system serial driver. In RS-485 mode, our special auto-enable feature allows the RS-485 ports to be viewed by the operating system as a COM: port. This allows the standard COM: driver to be utilized for RS-485 communications. Our on-board hardware automatically handles the RS-485 driver enable.

What's Included

The **ULTRA COMM+2I.PCI** is shipped with the following items. If any of these items is missing or damaged, contact the supplier.

- **ULTRA COMM+2I.PCI** Serial I/O Adapter
- Sealevel Software

Factory Default Settings

The **ULTRA COMM+2I.PCI** factory default settings are as follows:

Port #	Electrical Specification
Port 1	RS-422
Port 2	RS-422

To install the **ULTRA COMM+2I.PCI** using factory default settings, refer to Installation on page 7.

Card Setup

Electrical Interface Selection

Each port on the **ULTRA COMM+2I.PCI** has the ability to be used as RS-232, RS-422 or RS-485. This is selectable via two DIP-switches, SW1 & SW2. Please use the following examples to configure your adapter.

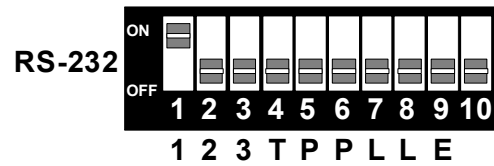

Figure 1- RS-232

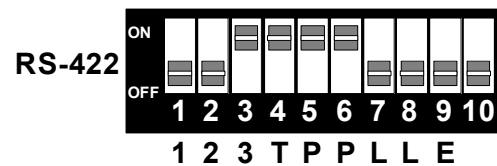

Figure 2 - RS-422

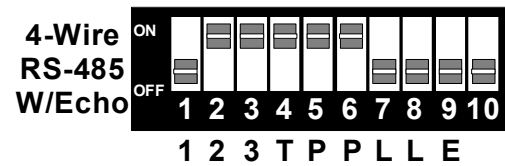

Figure 3 - RS-485, 4-Wire with Echo

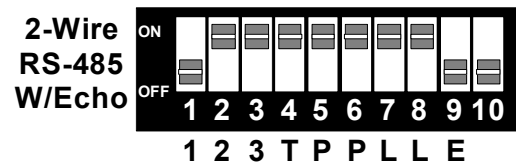

Figure 4 - RS-485 2-Wire with Echo

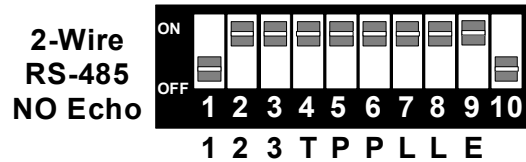

Figure 5 - RS-485, 2-wire without Echo

Line Termination

Typically, each end of the RS-485 bus must have line-terminating resistors (RS-422 terminates at the receive end only). A 120-ohm resistor is across each RS-422/485 input in addition to a 1K-ohm pull-up/pull-down combination that biases the receiver inputs. Switches SW1 and SW2 allow the user to customize this interface to their specific requirements. Each switch position corresponds to a specific portion of the interface. If multiple **ULTRA COMM+2I.PCI** adapters are configured in a RS-485 network, only the boards on each end should have jumpers T, P & P **ON**. Refer to the following table for each position's operation:

Name	Function
T	Adds or removes the 120 ohm termination.
P	Adds or removes the 1K ohm pull-down resistor in the RS-422/RS-485 receiver circuit (Receive data only).
P	Adds or removes the 1K ohm pull-up resistor in the RS-422/RS-485 receiver circuit (Receive data only).
L	Connects the TX+ to RX+ for RS-485 two wire operation.
L	Connects the TX- to RX- for RS-485 two wire operation.

RS-485 Enable Modes

RS-485 is ideal for multi-drop or network environments. RS-485 requires a tri-state driver that will allow the electrical presence of the driver to be removed from the line. The driver is in a tri-state or high impedance condition when this occurs. Only one driver may be active at a time and the other driver(s) must be tri-stated. The output modem control signal **Request To Send (RTS)** is typically used to control the state of the driver. Some communication software packages refer to RS-485 as RTS enable or RTS block mode transfer.

One of the unique features of the **ULTRA COMM+2I.PCI** is the ability to be RS-485 compatible without the need for special software or drivers. This ability is especially useful in Operating Systems where the lower level I/O control is abstracted from the application program. This ability means that the user can effectively use the **ULTRA COMM+2I.PCI** in an RS-485 application with existing (i.e. standard RS-232) software drivers.

Switches SW3 and SW4 are used to control the RS-485 mode functions for the driver circuit. The selections are 'RTS' enable (silk-screen 'RT' switch position 4) or 'Auto' enable (silk-screen 'AT' switch position 3). The 'Auto' enable feature automatically enables/disables the RS-485 interface. The 'RTS' mode uses the 'RTS' modem control signal to enable the RS-485 interface and provides backward compatibility with existing software products.

The RS-485 'Echo' is the result of connecting the receiver inputs to the transmitter outputs. Every time a character is transmitted; it is also received. This can be beneficial if the software can handle echoing (i.e. using received characters to throttle the transmitter) or it can confuse the system if the software does not. Position 9 of SW1 and SW2 is used to control the RS-485 enable/disable functions for the receiver circuit. To select the 'No Echo' mode place switch position 9 to the 'On' position (see Figure 5).

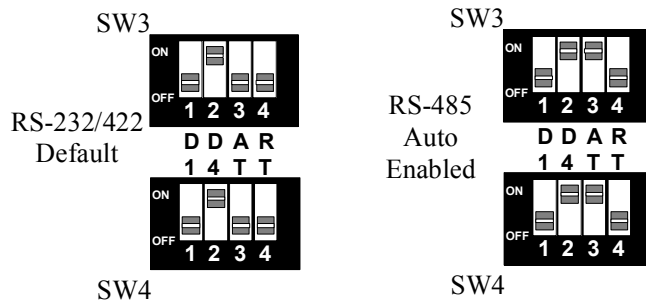

Figure 6 - RS-485 Enable modes

Clock Modes

The **ULTRA COMM+2I.PCI** employs a unique clocking option that allows the end user to select from divide by 4 and divide by 1 clocking modes. These modes are selected at switches SW3 & SW4.

To select the Baud rates commonly associated with COM: ports (i.e. 2400, 4800, 9600, 19.2, ... 115.2K Bps) set switch position 2 to the 'On' position (silk-screen D4). To select the maximum data rate (460.8K bps) set switch position 1 to the 'On' position (silk-screen D1).

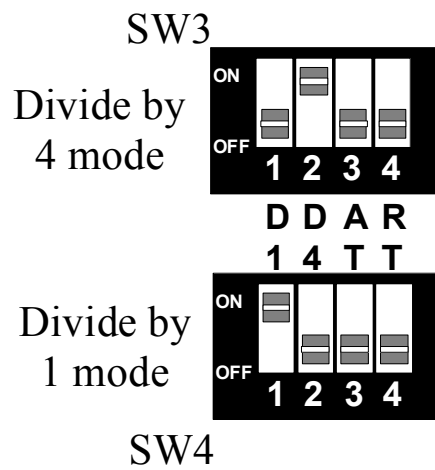

Figure 7 - Clocking Modes

Baud Rates and Divisors for the 'Div1' mode

The following table shows some common data rates and the rates you should choose to match them if using the adapter in the 'Div1' mode.

For this Data Rate	Choose this Data Rate
1200 bps	300 bps
2400 bps	600 bps
4800 bps	1200 bps
9600 bps	2400 bps
19.2K bps	4800 bps
57.6 K bps	14.4K bps
115.2 K bps	28.8K bps
230.4K bps	57.6K bps
460.8K bps	115.2K bps

If your communications package allows the use of Baud rate divisors, choose the appropriate divisor from the following table:

For this Data Rate	Choose this Divisor
1200 bps	384
2400 bps	192
4800 bps	96
9600 bps	48
19.2K bps	24
38.4K bps	12
57.6K bps	8
115.2K bps	4
230.4K bps	2
460.8K bps	1

Installation

Operating System Installation

For Windows Users

Start by choosing **Install Software at the beginning of the CD. Choose Asynchronous COM: Port Software, SeaCOM.**

Other Operating Systems

Refer to the appropriate section of the Serial Utilities Software.

System Installation

The **ULTRA COMM+2I.PCI** can be installed in any of the PCI expansion slots and contains several jumper straps for each port that must be set for proper operation.

1. Turn off PC power. Disconnect the power cord.
2. Remove the PC case cover.
3. Locate an available PCI slot and remove the blank metal slot cover.
4. Gently insert the **ULTRA COMM+2I.PCI** into the slot. Make sure that the adapter is seated properly.
5. Replace the screw.
6. Replace the cover.
7. Connect the power cord.

Installation is complete.

Technical Description

The Sealevel Systems **ULTRA COMM+2I.PCI** provides a PCI interface adapter with 2 isolated asynchronous serial ports providing a versatile interface, field selectable as RS-232 for modems, printers and plotters, as well as RS-422/485 for industrial automation and control applications. Isolation is important in installations where the equipment being connected to the PC is either far from the PC, or on a different power transformer circuit. Ground loop current is a commonly neglected and misunderstood phenomenon that leads to data loss and the destruction of communications interfaces.

The **ULTRA COMM+2I.PCI** utilizes the 16C850 UART. This chip features programmable baud rates, data format, interrupt control and industry leading 128-byte FIFOs.

Connector Pin Assignments

RS-232

	Name	Pin #	Mode
TD	Transmit Data	3	Output
RTS	Request To Send	7	Output
GND	Ground	5	
RD	Receive Data	2	Input
CTS	Clear To Send	8	Input

Note: These assignments meet EIA/TIA/ANSI-574 DTE for DB-9 type connectors.

RS-422/485

Signal	Name	Pin #	Mode
GND	Ground	5	
TX +	Transmit Data Positive	4	Output
TX-	Transmit Data Negative	3	Output
RTS+	Request To Send Positive	6	Output
RTS-	Request To Send Negative	7	Output
RX+	Receive Data Positive	1	Input
RX-	Receive Data Negative	2	Input
CTS+	Clear To Send Positive	9	Input
CTS-	Clear To Send Negative	8	Input

Specifications

Environmental Specifications

Specification	Operating	Storage
Temperature Range	0° to 50° C (32° to 122° F)	-20° to 70° C (-4° to 158° F)
Humidity Range	10 to 90% R.H. Non-Condensing	10 to 90% R.H. Non-Condensing

Manufacturing

- All Sealevel Systems Printed Circuit boards are built to UL 94V0 rating and are 100% electrically tested. These printed circuit boards are solder mask over bare copper or solder mask over tin nickel.

Power Consumption

Supply line	+5 VDC
Rating	480 mA

Mean Time Between Failures (MTBF)

Greater than 150,000 hours. (Calculated)

Physical Dimensions

Board length	6.5 inches	(16.51 cm)
Board Height including Goldfingers	4.2 inches	(10.66 cm)
Board Height excluding Goldfingers	3.875 inches	(9.84 cm)

Appendix A - Troubleshooting

A Serial Utility Diskette is supplied with the Sealevel Systems adapter and will be used in the troubleshooting procedures. By using this diskette and following these simple steps, most common problems can be eliminated without the need to call Technical Support.

1. Identify all I/O adapters currently installed in your system. This includes your on-board serial ports, controller cards, sound cards etc. The I/O addresses used by these adapters, as well as the IRQ (if any) should be identified.
2. Configure your Sealevel Systems adapter so that there is no conflict with currently installed adapters. No two adapters can occupy the same I/O address.
3. Make sure the Sealevel Systems adapter is using a unique IRQ. While the Sealevel Systems adapter does allow the sharing of IRQs, many other adapters (i.e. SCSI adapters & on-board serial ports) do not. The IRQ is typically selected via an on-board header block. Refer to the section on Card Setup for help in choosing an I/O address and IRQ.
4. Make sure the Sealevel Systems adapter is securely installed in a motherboard slot.
5. When running DOS or Windows 3.x refer to the supplied Sealevel Software and this User Manual to verify that the Sealevel Systems adapter is configured correctly. This software contains a diagnostic program 'SSD' that will verify if an adapter is configured properly. This diagnostic program is written with the user in mind and is easy to use.
6. For Windows95/98/ME/NT/2000, the diagnostic tool 'WinSSD' is installed in the SeaCOM folder on the Start Menu during the setup process. First find the ports using the Device Manager, then use 'WinSSD' to verify that the ports are functional.
7. Always use the Sealevel Systems diagnostic software when troubleshooting a problem. This will eliminate any software issues from the equation.

Appendix B - How To Get Assistance

1. Begin by reading through the Trouble Shooting Guide in Appendix A. If assistance is still needed please see below.
2. When calling for technical assistance, please have your user manual and current adapter settings. If possible, please have the adapter installed in a computer ready to run diagnostics.
3. Sealevel Systems provides an FAQ section on its web site. Please refer to this for many commonly asked questions. This section can be found at <http://www.sealevel.com/faq.htm> .
4. Visit Sealevel's website at www.sealevel.com for the latest software updates and newest manuals.
5. Technical support is available Monday to Friday from 8:00 a.m. to 5:00 p.m. eastern time. Technical support can be reached at (864) 843-4343.

RETURN AUTHORIZATION MUST BE OBTAINED FROM SEALEVEL SYSTEMS BEFORE RETURNED MERCHANDISE WILL BE ACCEPTED. AUTHORIZATION CAN BE OBTAINED BY CALLING SEALEVEL SYSTEMS AND REQUESTING A RETURN MERCHANDISE AUTHORIZATION (RMA) NUMBER.

Appendix C - Electrical Interface

RS-232

Quite possibly the most widely used communication standard is RS-232. This implementation has been defined and revised several times and is often referred to as RS-232 or EIA/TIA-232. The IBM PC computer defined the RS-232 port on a 9 pin D sub connector and subsequently the EIA/TIA approved this implementation as the EIA/TIA-574 standard. This standard is defined as the *9-Position Non-Synchronous Interface between Data Terminal Equipment and Data Circuit-Terminating Equipment Employing Serial Binary Data Interchange*. Both implementations are in wide spread use and will be referred to as RS-232 in this document. RS-232 is capable of operating at data rates up to 20 Kbps at distances less than 50 ft. The absolute maximum data rate may vary due to line conditions and cable lengths. RS-232 is a single ended or unbalanced interface, meaning that a single electrical signal is compared to a common signal (ground) to determine binary logic states. The RS-232 and the EIA/TIA-574 specification define two types of interface circuits, Data Terminal Equipment (DTE) and Data Circuit-Terminating Equipment (DCE). The **ULTRA COMM+2I.PCI** is a DTE device.

RS-422

The RS-422 specification defines the electrical characteristics of balanced voltage digital interface circuits. RS-422 is a differential interface that defines voltage levels and driver/receiver electrical specifications. On a differential interface, logic levels are defined by the difference in voltage between a pair of outputs or inputs. In contrast, a single ended interface, for example RS-232, defines the logic levels as the difference in voltage between a single signal and a common ground connection. Differential interfaces are typically more immune to noise or voltage spikes that may occur on the communication lines. Differential interfaces also have greater drive capabilities that allow for longer cable lengths. RS-422 is rated up to 10 Megabits per second and can have cabling 4000 feet long. RS-422 also defines driver and receiver electrical characteristics that will allow 1 driver and up to 32 receivers on the line at once. RS-422 signal levels range from 0 to +5 volts. RS-422 does not define a physical connector.

RS-485

RS-485 is backwardly compatible with RS-422; however, it is optimized for partyline or multi-drop applications. The output of the RS-422/485 driver is capable of being **Active** (enabled) or **Tri-State** (disabled). This capability allows multiple ports to be connected in a multi-drop bus and selectively polled. RS-485 allows cable lengths up to 4000 feet and data rates up to 10 Megabits per second. The signal levels for RS-485 are the same as those defined by RS-422. RS-485 has electrical characteristics that allow for 32 drivers and 32 receivers to be connected to one line. This interface is ideal for multi-drop or network environments. RS-485 tri-state driver (not dual-state) will allow the electrical presence of the driver to be removed from the line. Only one driver may be active at a time and the other driver(s) must be tri-stated. RS-485 can be cabled in two ways, two wire and four wire mode. Two wire mode does not allow for full duplex communication, and requires that data be transferred in only one direction at a time. For half-duplex operation, the two transmit pins should be connected to the two receive pins (Tx+ to Rx+ and Tx- to Rx-). Four wire mode allows full duplex data transfers. RS-485 does not define a connector pin-out or a set of modem control signals. RS-485 does not define a physical connector.

Appendix D - Ground Loop Phenomenon

What is Ground Loop?

Ground loop Phenomenon occurs when two (or more) pieces of equipment are connected together with a common ground and a different ground potential exists at each location. This current can cause the connected equipment to experience noise that in turn causes data transmission errors. In the extreme this ground current can cause equipment malfunction or even destruction.

Cabling Recommendations

When connecting the **ULTRA COMM+2I.PCI** in a RS-485 network, care should be taken that both ends of the network are not isolated from ground (see Figure 8). This “floating” ground condition could cause the capacitive or inductive coupling of voltages that will cause a break down in the DC to DC converter circuit or in the opto-isolator circuit. This condition will cause data errors and possibly destruction of the receiver circuit.

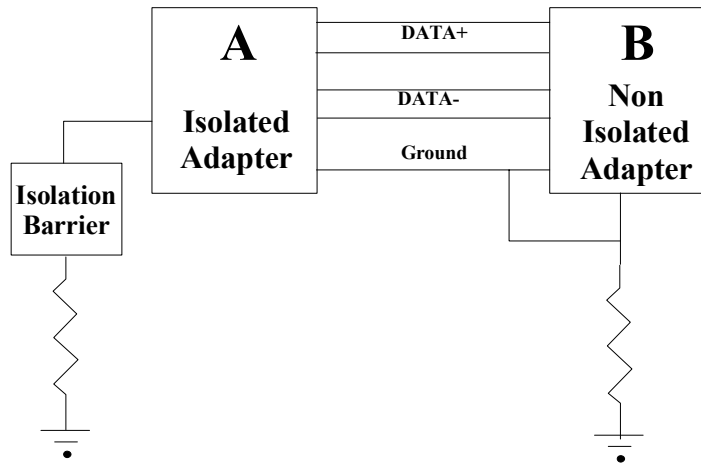

Figure 8 – **ULTRA COMM+2I.PCI** cabling example

Appendix E - Asynchronous Communications

Serial data communications implies that individual bits of a character are transmitted consecutively to a receiver that assembles the bits back into a character. Data rate, error checking, handshaking, and character framing (start/stop bits) are pre-defined and must correspond at both the transmitting and receiving ends.

Asynchronous communications is the standard means of serial data communication for PC compatibles and PS/2 computers. The original PC was equipped with a communication or COM: port that was designed around an 8250 Universal Asynchronous Receiver Transmitter (UART). This device allows asynchronous serial data to be transferred through a simple and straightforward programming interface. A start bit, followed by a pre-defined number of data bits (5, 6, 7, or 8) defines character boundaries for asynchronous communications. The end of the character is defined by the transmission of a pre-defined number of stop bits (usually 1, 1.5 or 2). An extra bit used for error detection is often appended before the stop bits.

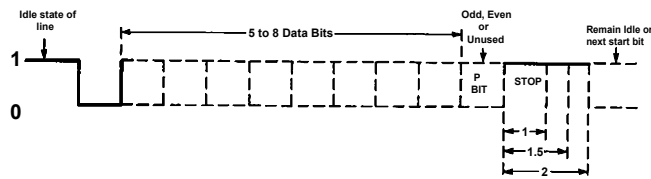
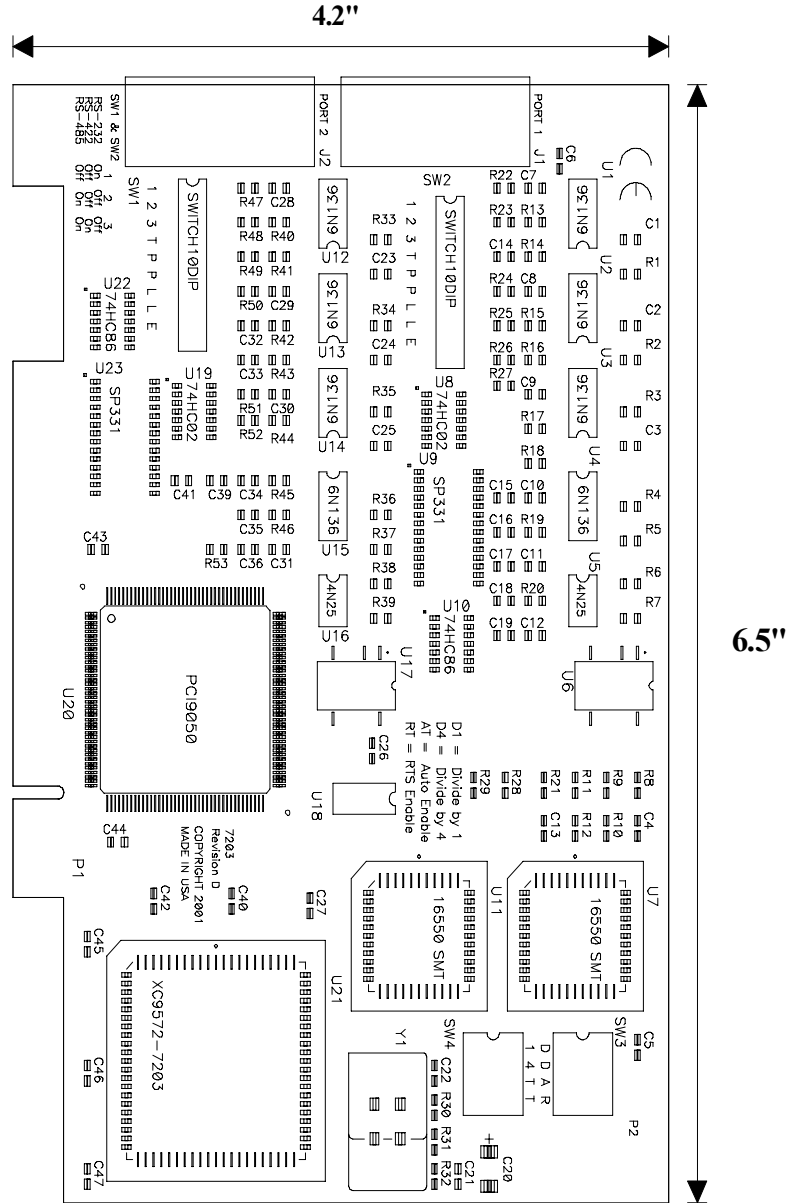

Figure 9 - Asynchronous Communications Bit Diagram

This special bit is called the parity bit. Parity is a simple method of determining if a data bit has been lost or corrupted during transmission. There are several methods for implementing a parity check to guard against data corruption. Common methods are called (E)ven Parity or (O)dd Parity. Sometimes parity is not used to detect errors on the data stream. This is referred to as (N)o parity. Because each bit in asynchronous communications is sent consecutively, it is easy to generalize asynchronous communications by stating that each character is wrapped (framed) by pre-defined bits to mark the beginning and end of the serial transmission of the character. The data rate and communication parameters for asynchronous communications have to be the same at both the transmitting and receiving ends. The communication parameters are baud rate, parity, number of data bits per character, and stop bits (i.e. 9600,N,8,1).

Appendix F - Silk-Screen



Appendix G - Compliance Notices

Federal Communications Commission Statement

FCC - This equipment has been tested and found to comply with the limits for Class A digital device, pursuant to Part 15 of the FCC Rules. These limits are designed to provide reasonable protection against harmful interference when the equipment is operated in a commercial environment. This equipment generates, uses, and can radiate radio frequency energy and, if not installed and used in accordance with the instruction manual, may cause harmful interference to radio communications. Operation of this equipment in a residential area is likely to cause harmful interference in such case the user will be required to correct the interference at his own expense.

EMC Directive Statement



Products bearing the CE Label fulfill the requirements of the EMC directive (89/336/EEC) and of the low-voltage directive (73/23/EEC) issued by the European Commission.

To obey these directives, the following European standards must be met:

- **EN55022 Class A** - “Limits and methods of measurement of radio interference characteristics of information technology equipment”
- **EN55024**-‘Information technology equipment Immunity characteristics Limits and methods of measurement.
- **EN60950 (IEC950)** - “Safety of information technology equipment, including electrical business equipment”

Warning

This is a Class A Product. In a domestic environment this product may cause radio interference in which case the user may be required to take adequate measures.

Always use cabling provided with this product if possible. If no cable is provided or if an alternate cable is required, use high quality shielded cabling to maintain compliance with FCC/EMC directives.

Warranty



Sealevel Systems, Inc. provides a lifetime warranty for this product. Should this product fail to be in good working order at any time during this period, Sealevel Systems will, at its option, replace or repair it at no additional charge except as set forth in the following terms. This warranty does not apply to products damaged by misuse, modifications, accident or disaster.

Sealevel Systems assumes no liability for any damages, lost profits, lost savings or any other incidental or consequential damage resulting from the use, misuse of, or inability to use this product. Sealevel Systems will not be liable for any claim made by any other related party.

RETURN AUTHORIZATION MUST BE OBTAINED FROM SEALEVEL SYSTEMS BEFORE RETURNED MERCHANDISE WILL BE ACCEPTED. AUTHORIZATION CAN BE OBTAINED BY CALLING SEALEVEL SYSTEMS AND REQUESTING A RETURN MERCHANDISE AUTHORIZATION (RMA) NUMBER.

Sealevel Systems, Incorporated
2779 Greenville Highway
P.O. Box 830
Liberty, SC 29657 USA
(864) 843-4343 FAX: (864) 843-3067
www.sealevel.com
email: support@sealevel.com

Technical Support is available from 8 a.m. to 5 p.m. Eastern time.
Monday - Friday

Trademarks

Sealevel Systems, Incorporated acknowledges that all trademarks referenced in this manual are the service mark, trademark, or registered trademark of the respective company.

Sealevel, Sealevel Software, Sealevel Systems are registered trademarks of sealevel Systems, Incorporated.

ULTRA COMM+2I.PCI is a trademark of Sealevel Systems, Incorporated.